

LOC	DIST	REV	DATE	BY	CHK	APPV
AD	00	0	29SEP2004	BC	RW	
		A	10JUL2006	DH	DB	

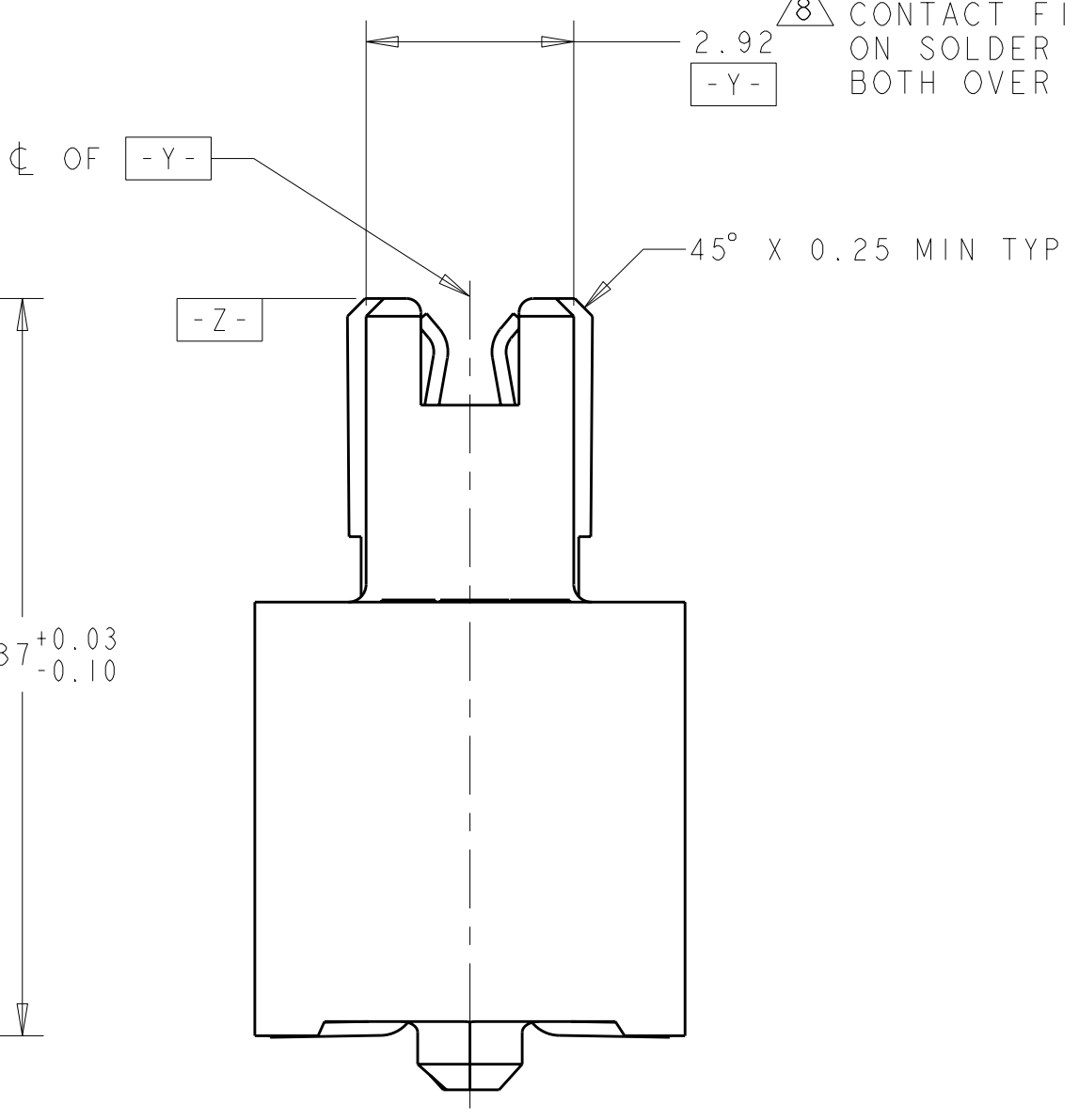

- 1. HOUSING MATERIAL: HIGH TEMPERATURE THERMOPLASTIC, COLOR; BLACK. CONTACT MATERIAL: PHOSPHOR BRONZE.
- 2. CONTACT FINISH: NICKEL UNDERPLATE ALL OVER, MATING SURFACES PLATED TO MEET PLI PERFORMANCE REQUIREMENTS OF INDUSTRY SPECIFICATION EIA-700AAAB, SOLDER TAILS PLATED TIN.
- 3. DATUM LOCATIONS AND BASIC DIMENSIONS TO BE ESTABLISHED BY THE CUSTOMER. CONSULT AMP ENGINEERING WHEN PLACING MULTIPLE CONNECTORS ON A PC BOARD.
- 4. PACKAGED IN TAPE ON REELS PER EIA-481.
- 5. 1.5±0.05 DIAMETER HOLE SHOULD BE USED IF PLACED ON PCB WITH VACUUM PLACEMENT EQUIPMENT.
- 6. SHORTER SOLDER LANDS MAY BE USED PER EIA 700AAAB, HOWEVER 2.4 LENGTH ASSURES OPTIMUM SOLDER FILLET REGARDLESS OF MANUFACTURER OF CONNECTOR.
- 7. REFERRED TO AS DIM H = 10.3±0.1 IN EIA 700AAAB SPECIFICATION.
- 8. CONTACT FINISH: 0.00381 MINIMUM MATTE TIN PER ASTM B 545 ON SOLDER AREA, 0.00127 MINIMUM GOLD PER ASTM B 488 ON MATING AREA, BOTH OVER 0.00127 MINIMUM NICKEL PER SAE-AMS-QQ-N-290 ON ENTIRE CONTACT.

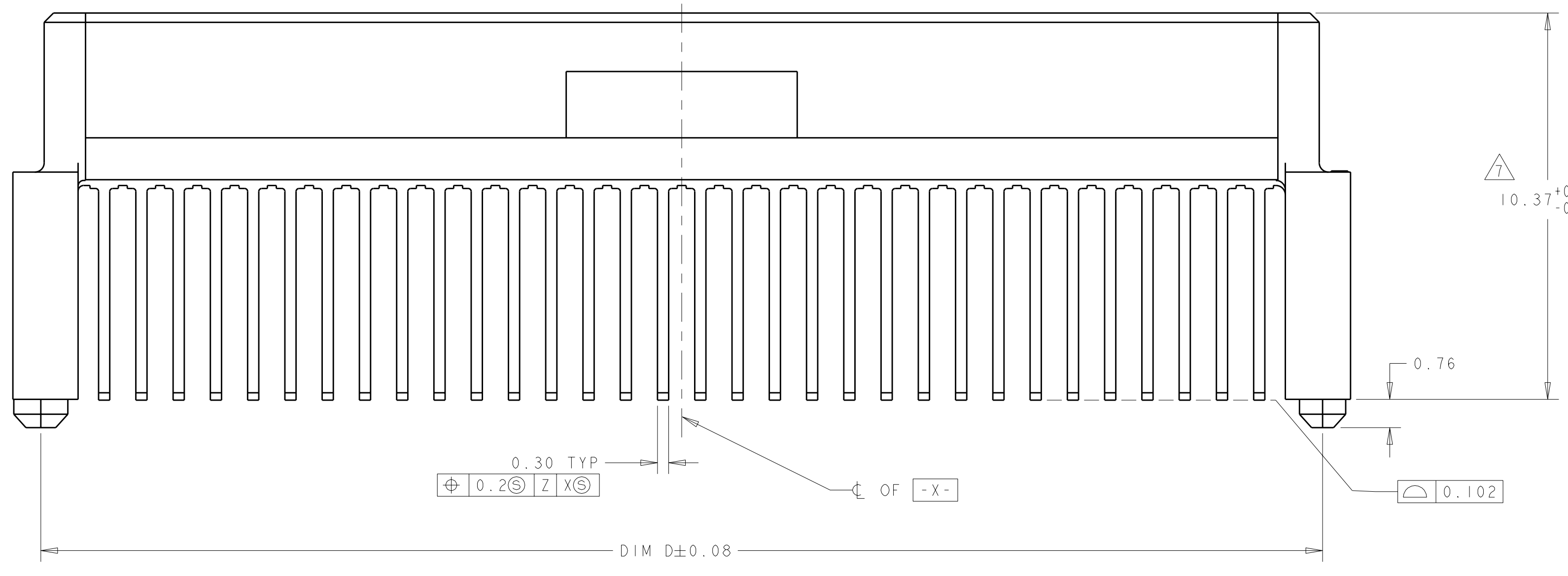
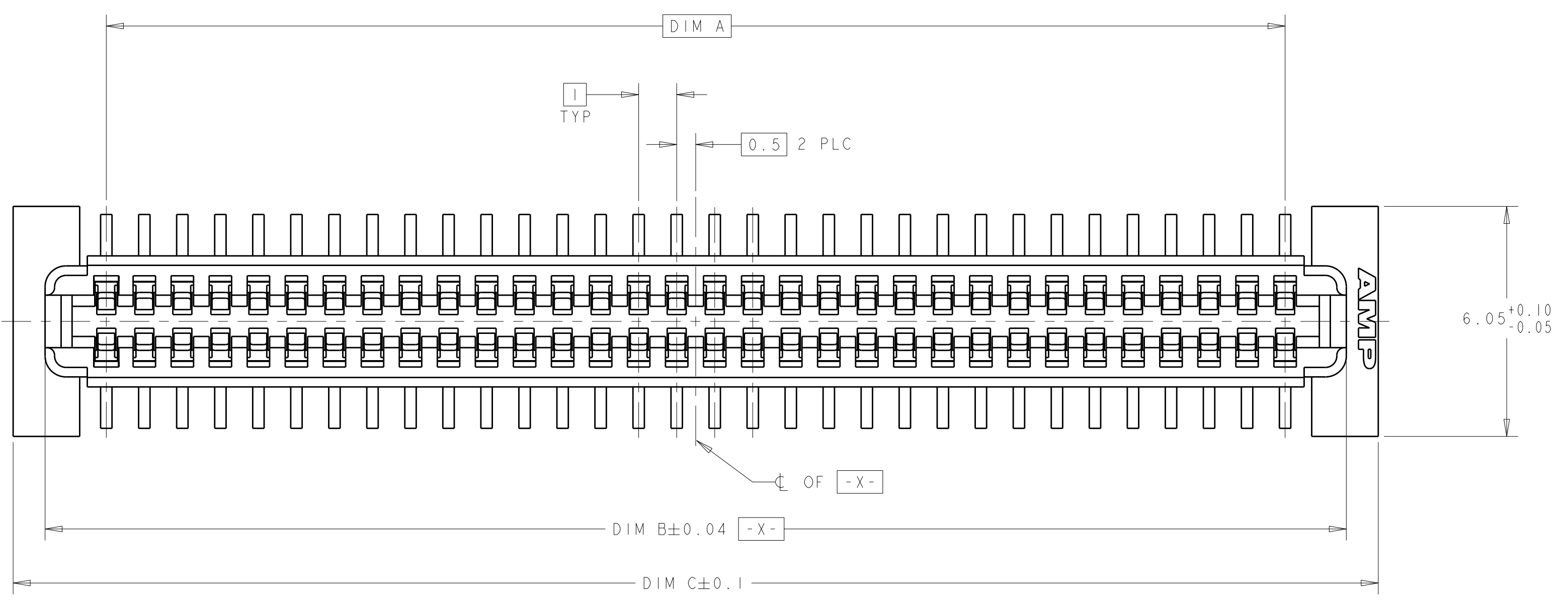
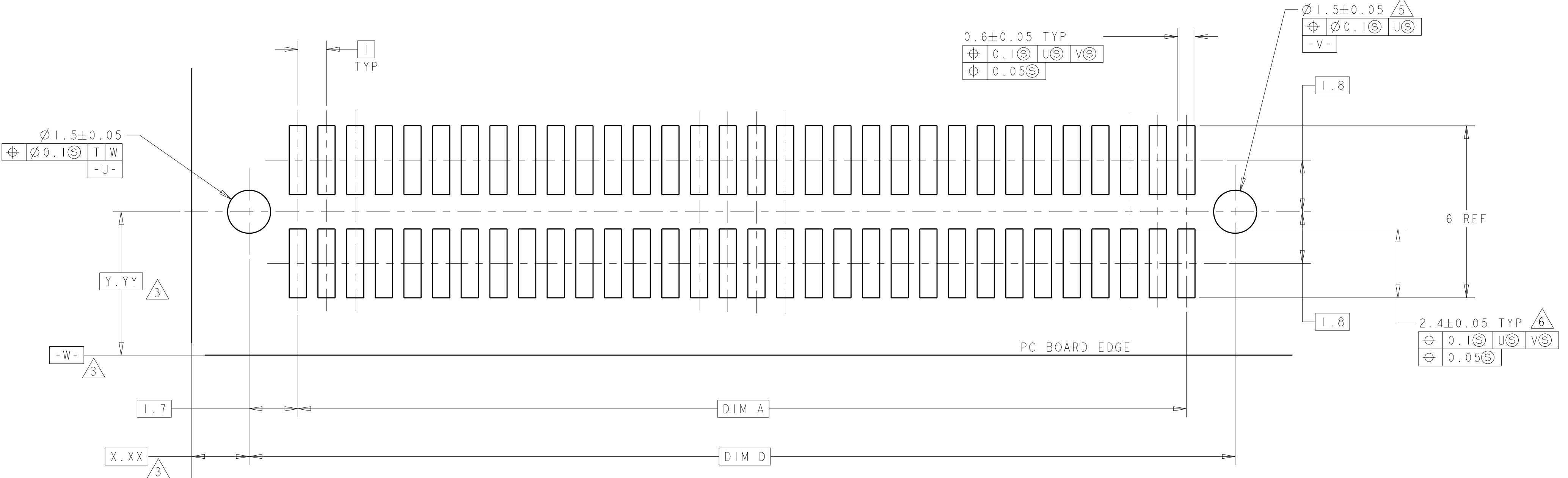

RECOMMENDED PC BOARD LAYOUT

FINISH	DIM D	DIM C	DIM B	DIM A	MATING CONNECTOR	STACK HGTS	POS	PART NO
8	44.4	45.9	44.22	41	5120527-2	15	84	1-5120524-2
8	44.4	45.9	44.22	41	5120526-2	14	84	1-5120524-2
8	34.4	35.9	34.22	31	5120527-1	15	64	1-5120524-1
8	34.4	35.9	34.22	31	5120526-1	14	64	1-5120524-1
2	44.4	45.9	44.22	41	5120527-2	15	84	5120524-2
2	44.4	45.9	44.22	41	5120526-2	14	84	5120524-2
2	34.4	35.9	34.22	31	5120527-1	15	64	5120524-1
2	34.4	35.9	34.22	31	5120526-1	14	64	5120524-1

DIMENSIONS: mm TOLERANCES UNLESS OTHERWISE SPECIFIED: 9 PLC ± 1 PLC ±0.03 5 PLC ±0.003 4 PLC ± ANGLES ±0°-1° FINISH SEE TABLE		DWN B. CARBO 29SEP04 CHK R. WERTZ 29SEP04 APPV R. WERTZ 29SEP04 PRODUCT SPEC 502-1079 APPLICATION SPEC 114-25045 WEIGHT CUSTOMER DRAWING		Tyco Electronics Harrisburg, PA 17105-3608 NAME RCPT ASSY, 1.0mm FH (IEEE1386) CONNECTOR SIZE CAGE CODE DRAWING NO RESTRICTED TO A 00779 C=5120524 1 OF 1 REV A	
--	--	--	--	---	--